



Standard Test Method for Determination of Low Levels of Heat Release Rate for Materials and Products Using an Oxygen Consumption Calorimeter¹

This standard is issued under the fixed designation E2965; the number immediately following the designation indicates the year of original adoption or, in the case of revision, the year of last revision. A number in parentheses indicates the year of last reapproval. A superscript epsilon (ϵ) indicates an editorial change since the last revision or reapproval.

1. Scope*

1.1 This fire-test-response standard provides a procedure for measuring the response of materials that emit low levels of heat release when exposed to controlled levels of radiant heating with or without an external igniter.

1.2 This test method differs from Test Method E1354 in that it prescribes a different specific test specimen size, specimen holder, test specimen orientation, a direct connection between the plenum and the top plate of the cone heater assembly to ensure complete collection of all the combustion gases (Fig. 1), and a lower volumetric flow rate for analyses via oxygen consumption calorimetry. It is intended for use on materials and products that contain only small amounts of combustible ingredients or components, such as test specimens that yield a peak heat release of $<200 \text{ kW/m}^2$ and total heat release of $<15 \text{ MJ/m}^2$.

NOTE 1—PMMA is typically used to check the general operation of a Cone Calorimeter. PMMA should not be used with this standard as the heat release rate is too high.

1.3 The rate of heat release is determined by measurement of the oxygen consumption as determined by the oxygen concentration and the flow rate in the exhaust product stream. The effective heat of combustion is determined from a concomitant measurement of test specimen mass loss rate, in combination with the heat release rate. Smoke development (an optional measurement) is measured by obscuration of light by the combustion product stream.

1.4 Test specimens shall be exposed to initial test heat fluxes generated by a conical radiant heater. External ignition, when used, shall be by electric spark. The test specimen testing orientation is horizontal, independent of whether the end-use application involves a horizontal or a vertical orientation.

1.5 Ignitability is determined as a measurement of time from initial exposure to time of sustained flaming.

¹ This test method is under the jurisdiction of ASTM Committee E05 on Fire Standards and is the direct responsibility of Subcommittee E05.23 on Combustibility.

Current edition approved Nov. 1, 2022. Published November 2022. Originally approved in 2015. Last previous edition approved in 2022 as E2965-22. DOI: 10.1520/E2965-22A.

1.6 This test method has been developed for use for material and product evaluations, mathematical modeling, design purposes, and development and research. Examples of material test specimens include portions of an end-use product or the various components used in the end-use product.

1.7 The values stated in SI units are to be regarded as standard. No other units of measurement are included in this standard.

1.8 *This standard is used to measure and describe the response of materials, products, or assemblies to heat and flame under controlled conditions, but does not by itself incorporate all factors required for fire hazard or fire risk assessment of the materials, products, or assemblies under actual fire conditions.*

1.9 *Fire testing is inherently hazardous. Adequate safeguards for personnel and property shall be employed in conducting these tests.*

1.10 *This standard does not purport to address all of the safety concerns, if any, associated with its use. It is the responsibility of the user of this standard to establish appropriate safety, health, and environmental practices and determine the applicability of regulatory limitations prior to use. For specific hazard statements, see Section 7.*

1.11 *This international standard was developed in accordance with internationally recognized principles on standardization established in the Decision on Principles for the Development of International Standards, Guides and Recommendations issued by the World Trade Organization Technical Barriers to Trade (TBT) Committee.*

2. Referenced Documents

2.1 ASTM Standards:

D5865 Test Method for Gross Calorific Value of Coal and Coke

E176 Terminology of Fire Standards

E603 Guide for Room Fire Experiments

E906 Test Method for Heat and Visible Smoke Release Rates for Materials and Products Using a Thermopile Method

E1354 Test Method for Heat and Visible Smoke Release

*A Summary of Changes section appears at the end of this standard

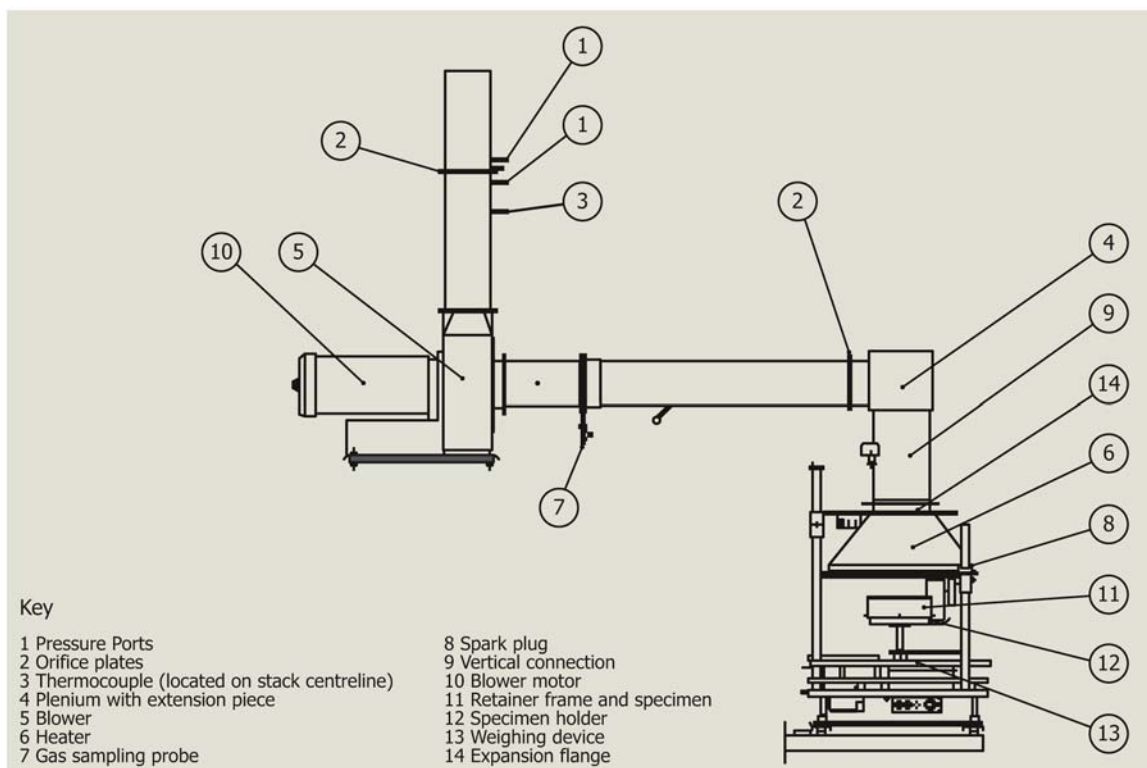

FIG. 1 Modified Cone Calorimeter

Rates for Materials and Products Using an Oxygen Consumption Calorimeter

2.2 ISO Standards

ISO 5657-1986 (E) Fire Tests—Reaction to Fire—Ignitability of Building Materials

ISO 5725-2 (1994) Accuracy (Trueness and Precision) of Measurement Methods and Results—Part 2: Basic Method for the Determination of Repeatability and Reproducibility of a Standard Measurement Method

3. Terminology

3.1 Definitions: For definitions of terms used in this test method, refer to Terminology E176.

3.1.1 *effective heat of combustion, n*—the amount of heat generated per unit mass lost by a material, product or assembly, when exposed to specific fire test conditions (contrast *gross heat of combustion*).

3.1.1.1 Discussion—The effective heat of combustion depends on the test method, and is determined by dividing the measured heat release by the mass loss during a specified period of time under the specified test conditions. Typically, the specified fire test conditions are provided by the specifications of the fire test standard that cites effective heat of combustion as a quantity to be measured. For certain fire test conditions, involving very high heat and high oxygen concentrations under high pressure, the effective heat of combustion will approximate the gross heat of combustion. More often, the fire test conditions will represent or approximate certain real fire exposure conditions, and the effective heat of combustion is the appropriate measure. Typical units are kJ/g or MJ/kg.

3.1.2 *gross heat of combustion, n*—the maximum amount of heat per unit mass that theoretically can be released by the combustion of a material, product, or assembly; it can be determined experimentally and only under conditions of high pressure and in pure oxygen (contrast *effective heat of combustion*).

3.1.3 *heat flux, n*—heat transfer to a surface per unit area, per unit time (see also *initial test heat flux*).

3.1.3.1 Discussion—The heat flux from an energy source, such as a radiant heater, can be measured at the initiation of a test (such as Test Method E1354 or Test Method E906) and then reported as the initial test heat flux, with the understanding that the burning of the test specimen can generate additional heat flux to the specimen surface. The heat flux can also be measured at any time during a fire test, for example as described in Guide E603, on any surface, and with measurement devices responding to radiative and convective fluxes. Typical units are kW/m², W/cm², or BTU/(s ft²).

3.1.4 *ignitability, n*—the propensity for ignition, as measured by the time to sustained flaming, in seconds, at a specified heating flux.

3.1.5 *initial test heat flux, n*—the heat flux set on the test apparatus at the initiation of the test (see also *heat flux*).

3.1.5.1 Discussion—The initial test heat flux is the heat flux value commonly used when describing or setting test conditions.

3.1.6 *oxygen consumption principle, n*—the expression of the relationship between the mass of oxygen consumed during combustion and the heat released.

3.1.7 *smoke obscuration, n*—reduction of light transmission by smoke, as measured by light attenuation.

3.2 *Definitions of Terms Specific to This Standard:*

3.2.1 *heat release rate, n*—the heat evolved from the specimen, per unit of time.

3.2.2 *net heat of combustion, n*—the oxygen bomb (see Test Method **D5865**) value for the heat of combustion, corrected for gaseous state of product water.

3.2.2.1 *Discussion*—The net heat of combustion differs from the gross heat of combustion, in that the former assesses the heat per unit mass generated from a combustion process that ends with water in the gaseous state, while the latter ends with water in the liquid state.

3.2.3 *orientation, n*—the plane in which the exposed face of the specimen is located during testing, either vertical or horizontal facing up.

3.2.4 *sustained flaming, n*—existence of flame on or over most of the specimen surface for periods of at least 4 s.

3.2.4.1 *Discussion*—Flaming of less than 4 s duration is identified as flashing or transitory flaming.

3.3 *Symbols:*

- A_s = nominal test specimen exposed surface area, 0.0225 m².
- C = calibration constant for oxygen consumption analysis, m^{1/2} – kg^{1/2} – K^{1/2}.
- Δh_c = net heat of combustion, kJ/kg.
- $\Delta h_{c,eff}$ = effective heat of combustion, kJ/kg.
- I = actual beam intensity.
- I_o = beam intensity with no smoke.
- k = smoke extinction coefficient, m⁻¹.
- L = extinction beam path length, m.
- m = test specimen mass, kg.
- m_f = final test specimen mass, kg.
- m_i = initial test specimen mass, kg.
- m = test specimen mass loss rate, kg/s.
- ΔP = orifice meter pressure differential, Pa.
- Q''_{tot} = total heat released, kJ/m² (Note that kJ \equiv kW·s).
- \dot{q}'' = heat release rate, kW.
- \dot{q}'' = heat release rate per unit area, kW/m².
- \dot{q}''_{max} = maximum heat release rate per unit area (kW/m²).
- \dot{q}''_{180} = average heat release rate, per unit area, over the time period starting at t_{ig} and ending 180 s later (kW/m²).
- r = repeatability (the units are the same as for the variable being characterized).
- R = reproducibility (the units are the same as for the variable being characterized).
- r_O = stoichiometric oxygen/fuel mass ratio (–).
- s_r = sample-based standard deviation estimate for repeatability (same units as r).
- s_R = sample-based standard deviation estimate for reproducibility (same units as R).
- t = time, s.
- t_d = oxygen analyzer delay time, s.
- t_{ig} = time to sustained flaming (s).
- ρ = density (kg/m³).
- Δt = sampling time interval, s.
- T_e = absolute temperature of gas at the orifice meter, K.

- V = volume exhaust flow rate, measured at the location of the laser photometer, m³/s.
- X_{O_2} = oxygen analyzer reading, mole fraction O₂ (–).
- $X_{O_2}^0$ = initial value of oxygen analyzer reading (–).
- $X_{O_2}^1$ = oxygen analyzer reading, before delay time correction (–).
- σ_f = specific extinction area, for smoke, m²/kg.
- σ_r = repeatability standard deviation (same units as r).
- σ_R = reproducibility standard deviation (same units as R).

4. Summary of Test Method

4.1 This test method is based on the observation that, generally, the net heat of combustion is directly related to the amount of oxygen required for combustion. The relationship, known as the oxygen consumption principle, is that approximately 13.1 × 10³ kJ of heat are released per 1 kg of oxygen consumed. Test specimens in the test are burned in ambient air conditions, while being subjected to a predetermined initial test heat flux. In the test, the test specimens are exposed to a pre-determined initial test heat flux, either with or without the added use of a spark igniter. The primary measurements are oxygen concentrations and exhaust gas flow rate, which are used to determine heat release rate and total heat released. Additional measurements include the mass-loss rate of the test specimen, the time to sustained flaming and (optionally) smoke obscuration, or as required in the relevant material or performance standard.

4.2 Prior to testing any material using this test method, assurance shall be given to the test laboratory that the material to be tested will not generate excessive heat when tested, for example by complying with **4.2.1** or with **4.2.2**.

4.2.1 The material shall be tested to Test Method **E1354** at the same initial test heat flux and yield a peak heat release rate of <200 kW/m² and a total heat release of <15 MJ/m², as required in **11.1**.

4.2.2 In lieu of conducting the test with Test Method **E1354**, the test requestor is permitted to provide alternate evidence that the material to be tested will meet the heat release requirements of **4.2**, as required in **11.2**.

5. Significance and Use

5.1 This test method is used primarily to determine the heat evolved in, or contributed to, a fire involving materials or products that emit low levels of heat release. The recommended use for this test method is for materials with a total heat release rate measured of less than 10 MJ over the first 20 min test period, and which do not give peak heat release rates of more than 200 kW/m² for periods extending more than 10 s. Also included is a determination of the effective heat of combustion, mass loss rate, the time to sustained flaming, and (optionally) smoke production. These properties are determined on small size test specimens that are representative of those in the intended end use.

5.2 This test method is applicable to various categories of products and is not limited to representing a single fire scenario.